



NEW
NUEVO

OX

WORLDWIDE
www.oxworldwide.com

04.

OX SPREADER BEAMS
BALANCINES
SEPARADORES OX

CAPACITY
CAPACIDAD
9t to 1350t



DNV-0377-0378
TYPE APPROVED PRODUCT

ESPAÑOL

ENGLISH

C/ MARE DE DÉU DE NÚRIA, 4 PARC IND. SALAS - 808830 SANT BOI DE LLOBREGAT BARELONA
TEL. (+34) 93 289 54 74 · info@oxworldwide.com · www.oxworldwide.com

ED. 09.18

OX SPREADER BEAMS
BALANCINES SEPARADORES



29

SPREADER BEAM PARTS
PARTES DEL BALANCIN

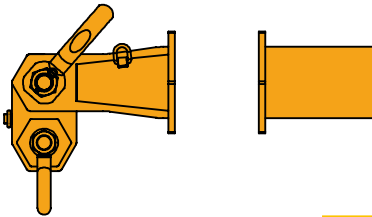

31

WORKING ANGLES
ÁNGULOS DE TRABAJO

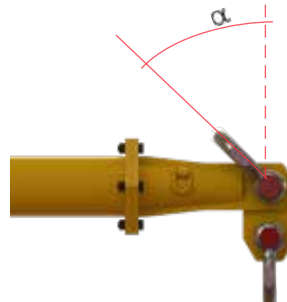

32

CAPACITY TABLES
TABLAS DE CAPACIDAD



33

COMPONENT TABLES
TABLAS DE COMPONENTES
9t-1350t



40

POSSIBLE APPLICATIONS
POSIBLES APLICACIONES

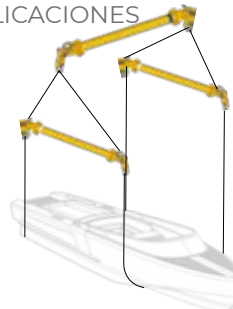

47

CORNERS AND CONE ADAPTERS
CORNERS Y ADAPTADORES CÓNICOS



49

NEW VERSION 2.0 SPREADERS BEAM WITH THE GREATEST CAPACITY ON THE MARKET

Better and higher capacities (by size) and lengths than any other manufacturer certified by DNV

NUEVA VERSION 2.0 LOS SEPARADORES CON MAYOR CAPACIDAD DEL MERCADO

Capacidades mejores y más altas (por tamaño) y longitudes que cualquier otro fabricante certificado por DNV



OX SPREADER BEAMS

¿Do you need mobility and versatility in your movement of huge loads?

With OX spreader beams you have a complete modular range, that allows to assembly on the spot one or multiple spreader beams of 1 to 36 m. long and with 9 to 1350 tons capacity.

- Available in stock up to 170 tons for sale and rental.
- The Spreader beam is designed and manufactured in accordance with current norms.
- Reduced size and weight, that eases and reduces transportation, storage and installation costs.
- Easy and fast assembly, following the steps on the instructions manual.
- Economic product, replaces a whole range of spreader and beams.
- It is a modular system, you just have to add or remove sections in order to have a new spreader beam adjusted to your needs for any lifting work.
- For a lifting of multiple anchorage points you can combine spreader beams vertically or form a rectangle with the corners.
- All series can be delivered with shackles.
- Series with huge loads use wide body shackles to avoid any damage on the slings.

BALANCINES OX

¿Necesita movilidad y versatilidad en sus movimientos de grandes cargas?

Con los balancines separadores OX dispone de una gama modular completa, permite ensamblar sobre el terreno uno o varios separadores de carga con longitudes de 1 metro a 36 metros y con capacidad de 9 a 1350 toneladas.

- Disponible en stock hasta 170 toneladas para la venta y para alquiler.
- Conforme a las normas en vigor.
- Peso y medidas reducidas, que facilita y reduce los costes de transporte, de almacenaje y de instalación.
- Montaje rápido y sencillo, siguiendo los pasos del manual de utilización.
- Producto económico, reemplaza toda una serie de balancines o separadores.
- Modular, es suficiente sacar o añadir uno o varios tramos, para obtener un nuevo separador de longitud y características diferentes.
- Para una carga en la que se necesiten varios puntos de anclaje se pueden utilizar separadores en cascada o formar un rectángulo con los corners.
- Todos los modelos se pueden entregar con grilletes lira a petición del cliente.
- Los modelos de más carga utilizan grilletes de cuerpo ancho para no dañar las eslingas.

OX SPREADER BEAM BALANCINES SEPARADORES OX

MATERIAL

Structural steel and high elastic limit steel, supplied with quality certificate 3.1, are used for the manufacture of the spreader beams.

FINISH

The basic finishing of our products consists of Sa 2.5 sandblasting according to ISO 8501-1 standards. One layer of zinc phosphate epoxy primer with a thickness of 50 microns and two layers of polyurethane enamel colour RAL 1028. Other grades on request.

IN ACCORDANCE WITH

We comply with the provisions in the directives of the European Parliament and from the Council 2006/42/CE, on 17th May 2006, regarding the approach of several legislations of the member states on machinery and 2014/30/UE, on 26th February 2014, regarding the approach of several legislations of the member states about electromagnetic compatibility, and it has been manufactured in accordance with the following norms:

- UNE-EN ISO 12100: 2012.** Safety of machinery - General principles for design - Risk assessment and risk reduction
- UNE-EN 13155:2004+A2:2009.** Cranes. Security, static equipment for lifting loads.
- UNE-EN ISO 3834-2:2006.** Quality requirements for fusion welding of metallic materials - Part 2: Comprehensive quality requirement

We have obtained **DNV-GL quality certification**, for our **Spreader Beams** from 9 tons to 1350 tons of load, a requirement that proves that we work with the highest quality standards.

-Certificates DNV

- DNV GL standard **DNVGL-ST-0378**
Standard for offshore and platform lifting appliances
- DNV GL standard **DNVGL-ST-0377**
Standard for shipboard lifting.



MATERIAL

Para la fabricación de los balancines separadores se utiliza acero estructural y aceros de alto límite elástico, suministrados con certificado de calidad 3.1.

ACABADO

El acabado básico de nuestros productos consiste en el chorreado Sa 2,5 según normas ISO 8501-1. Una capa de imprimación epoxi fosfato de zinc con 50 micras de espesor y dos capas de esmalte poliuretano color RAL 1028. Otras calidades, solicitar oferta.

CONFORME

Cumplimos con las disposiciones de las directivas del Parlamento Europeo y del Consejo 2006/42/CE, de 17 de mayo de 2006, relativa a la aproximación de legislaciones de los estados miembros sobre máquinas y Directiva 2014/30/UE del Parlamento Europeo y del Consejo, de 26 de febrero de 2014, sobre la armonización de las legislaciones de los Estados miembros en materia de compatibilidad electromagnética, y ha sido fabricada de acuerdo con las siguientes normas armonizadas:

- UNE-EN ISO 12100: 2012.** Seguridad de las máquinas. Principios generales para el diseño. Evaluación del riesgo y reducción del riesgo.
- UNE-EN 13155:2004+A2:2009.** Grúas. Seguridad. Equipos amovibles de elevación de carga.
- UNE-EN ISO 3834-2:2006.** Requisitos de calidad para el soldeo por fusión de materiales metálicos. Parte 2: Requisitos de calidad completos.

Hemos obtenido la certificación de calidad DNV-GL, para nuestros Balancines Separadores o Spreader Beams de 9 toneladas a 1350 toneladas de carga, un requisito más para certificar que trabajamos con los más altos estándares de calidad.

-Certificados DNV

- **DNV GL** standard **DNVGL-ST-0378**
Standard for offshore and platform lifting appliances
- **DNV GL** standard **DNVGL-ST-0377**
Standard for shipboard lifting appliances



FOR MORE INFO GO INTO WWW.OXWORLDWIDE.COM
PARA MÁS INFO ENTRAR EN WWW.OXWORLDWIDE.COM.

SPREADER BEAM PARTS

PARTES DEL BALANCIN SEPARADOR



LIFTING POINT (ONLY FOR HANDLING, NEVER FOR LOADING)
 PUNTO DE ELEVACION DEL TUBO SOLO PARA MANIPULACION, NUNCA PARA CARGA

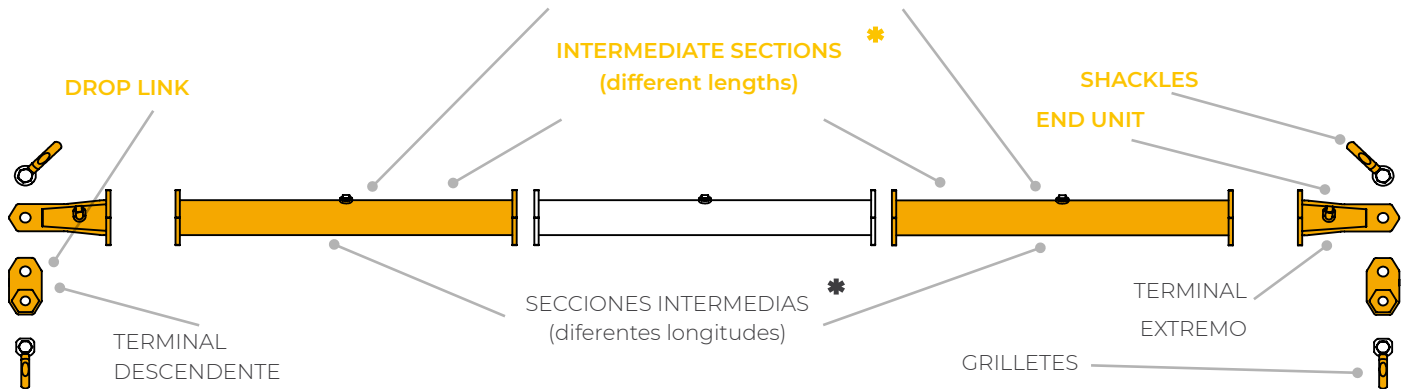

* Can be placed a maximum of 5 intermediate sections in each spreader up till the 170 tn spreader and 6 int. sections from the 250 tn and upwards.

* Se pueden colocar como máximo 5 secciones intermedias en cada spreader hasta el modelo de 170 tn y 6 secciones a partir del modelo de 250 tn.



SHACKLES - GRILLETES

Model/Modelo	TOP/Superior	BOTTOM/Inferior
SB-09	6,5 BOW	4,75 BOW
SB-17	12 BOW	8,5 BOW
SB-24	17 BOW	12 BOW
SB-34	25 BOW	17 BOW
SB-50	35 BOW	25 BOW
SB-70	55 BOW	35 BOW
SB-110	85 BOW	55 BOW
SB-110/170	120 BOW	85 BOW
SB-170	120 BOW	85 BOW
SB-170/250	200 WIDE BODY	125 WIDE BODY
SB-250	200 WIDE BODY	125 WIDE BODY
SB-250/400	300 WIDE BODY	200 WIDE BODY
SB-400	300 WIDE BODY	200 WIDE BODY
SB-400/600	400 WIDE BODY	300 WIDE BODY
SB-600	400 WIDE BODY	300 WIDE BODY
SB-600/800	500 WIDE BODY	400 WIDE BODY
SB-800	500 WIDE BODY	400 WIDE BODY
SB-1350	800 WIDE BODY	700 WIDE BODY

BOW SHACKLE
GRILLETE LIRA



BOW SHACKLE SAFETY PIN
GRILLETE LIRA TUERCA Y PASADOR



WIDE BODY SHACKLE
GRILLETE CUERPO ANCHO



WORKING ANGLES / LOADS / LENGTHS. ÁNGULOS DE TRABAJO / CARGA / LONGITUDES.

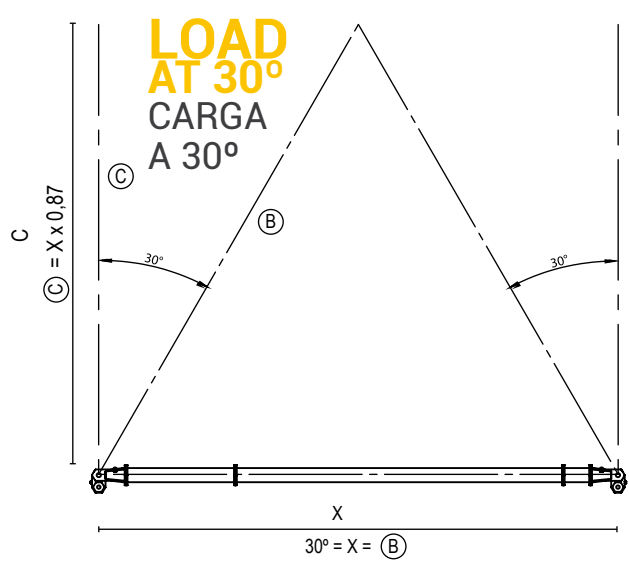
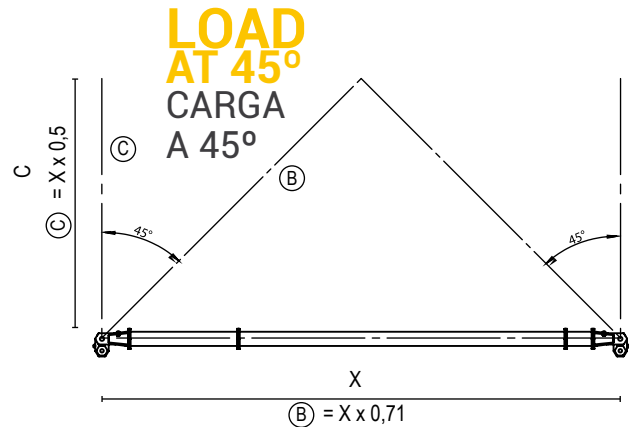
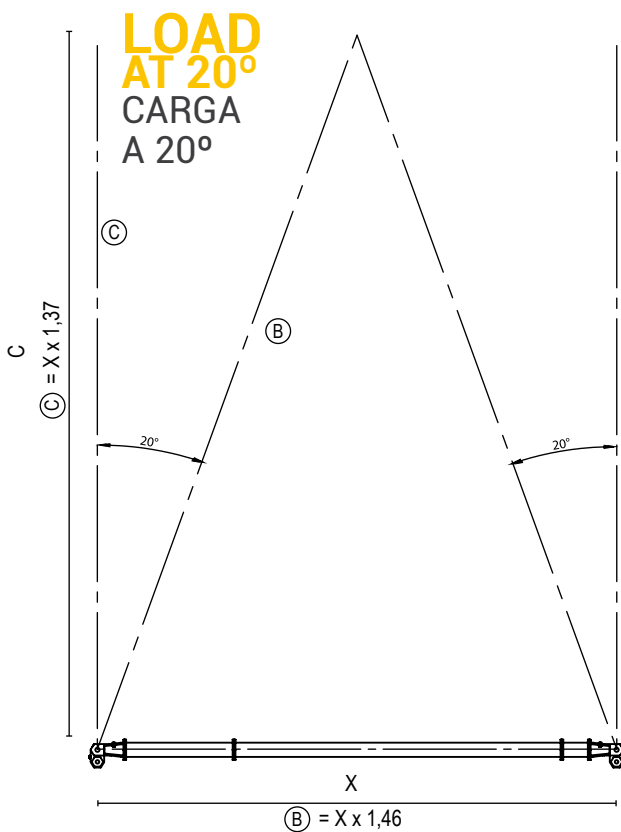

BE CAREFUL!!! ATENCIÓN!!!

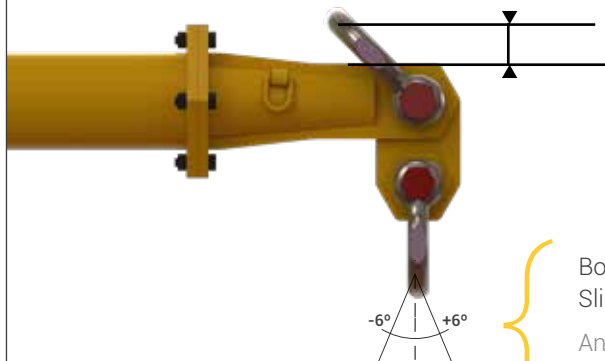

SEPARATION / SEPARACIÓN

Slings or hooks should never contact the spreader beam.
La eslinga o ganchos no debe, en ningún momento, tocar el balancín.

Bottom Angle.
Slings angles in the bottom: never more than $\pm 6^\circ$
Angulo Inferior.
Ángulos de las eslingas inferiores, nunca más de $\pm 6^\circ$

LOAD AT 30° AND MAX 170T
CARGAS A 30° MAX. 170T

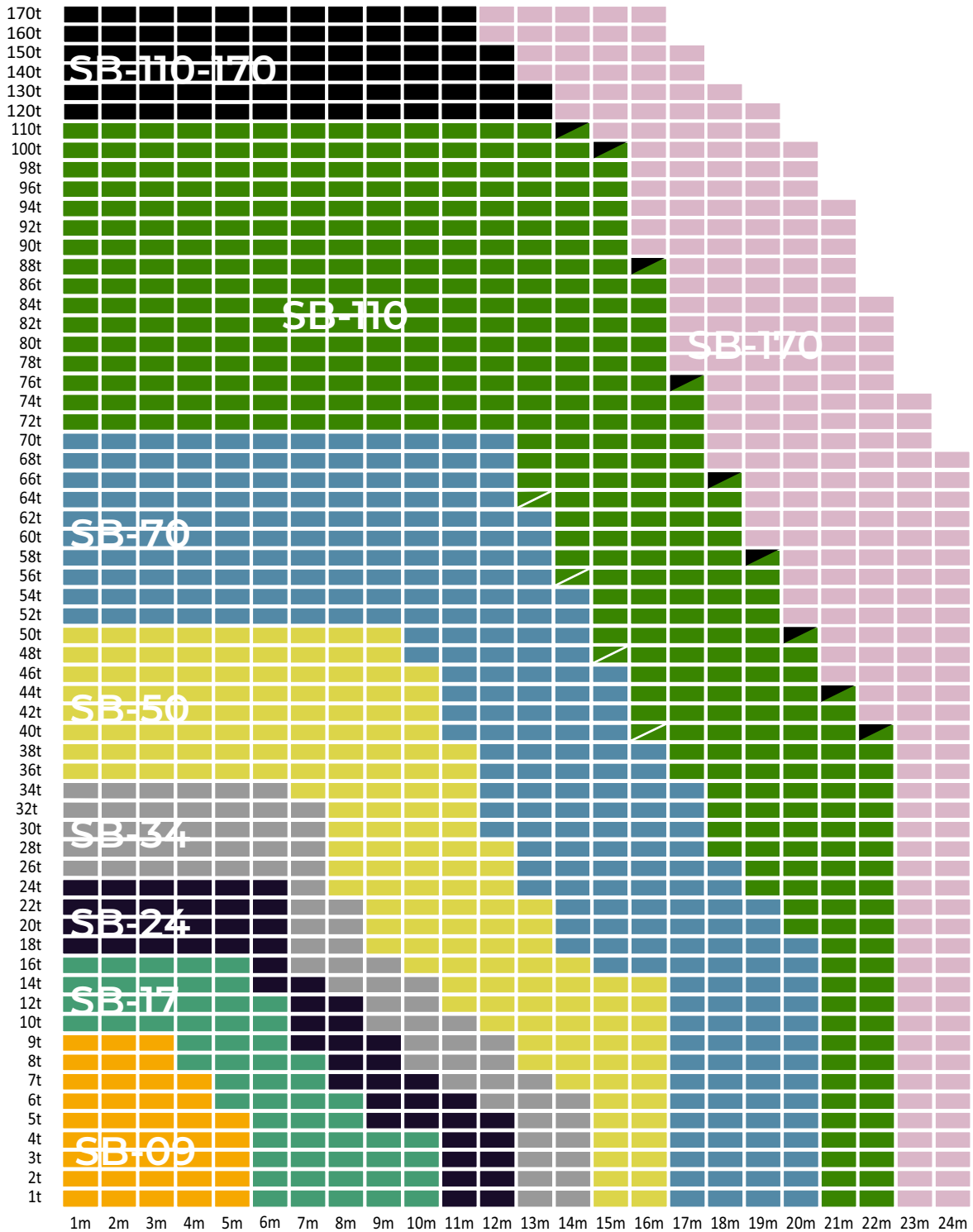

LOAD AT 30° AND MAX 1350T
CARGAS A 30° MAX. 1350T

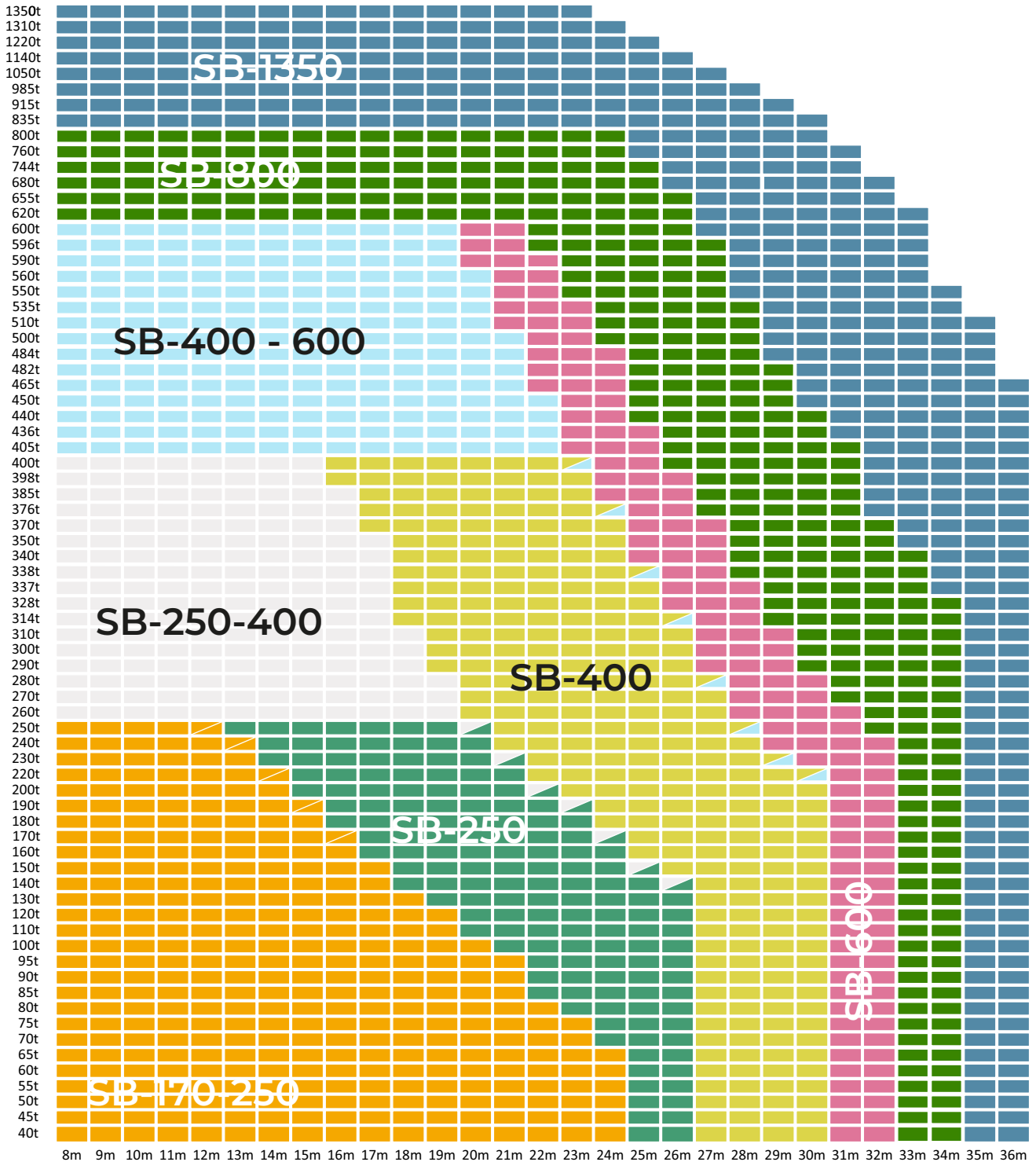

EXAMPLE IDENTIFICATION TAG
EJEMPLO DE PLACA DE IDENTIFICACION



OX-SB09

span (m) longitud (m)	0,5m	1m	2m	3m	4m	5m
45° WLL (t)	9	9	9	7,6	4,6	3
30° WLL (t)	9	9	9	9	7,6	5,2
20° WLL (t)	9	9	9	9	9	8

OX-SB17

span (m) longitud (m)	0,5-4m	5m	6m	7m	8m	9m	10m
45° WLL (t)	17	11	7	5	3,8	2,8	2,4
30° WLL (t)	17	17	12	8	6	4,7	4,2
20° WLL (t)	17	17	17	13	10	7,5	6,6

OX-SB24

span (m) longitud (m)	0,5-4m	5m	6m	7m	8m	9m	10m	11m	12m
45° WLL (t)	24	18	13	9	7	5,5	4,5	3,5	3
30° WLL (t)	24	24	24	15,5	12	9,5	7,5	6	5
20° WLL (t)	24	24	24	24	18	15	12	9	8

OX-SB34

span (m) longitud (m)	1-5m	6m	7m	8m	9m	10m	11m	12m	13m	14m
45° WLL (t)	34	26	20	13	10	8	6,5	5,4	4,5	3,8
30° WLL (t)	34	34	33	22	17	14	11	9	7,5	6,5
20° WLL (t)	34	34	34	34	27	22	17,5	14,5	12	10

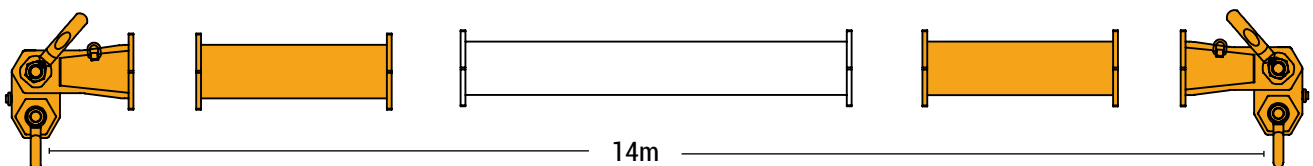

*On average, we have 30% more load capacity in the longer ones

*De media, tenemos un 30% más de capacidad de carga en las de mayor longitud

CAPACITY TABLES

TABLAS DE CAPACIDAD

EXAMPLE
IDENTIFICATION TAG
EJEMPLO DE PLACA DE
IDENTIFICACION



OX-SB50

span (m) longitud (m)	1-7m	8m	9m	10m	11m	12m	13m	14m	15m	16m
45° WLL (t)	50	41	33	27	22	17	13	10	9	8
30° WLL (t)	50	50	50	46	38	29	22	17	15	14
20° WLL (t)	50	50	50	50	50	46	35	27	25	22

OX-SB70

span (m) longitud (m)	1-9m	10m	11m	12m	13m	14m	15m	16m	17m	18m	19m	20m
45° WLL (t)	70	64	54	45	38	33	28	24	21	17	14	12
30° WLL (t)	70	70	70	70	65	57	48	41	36	29	24	21
20° WLL (t)	70	70	70	70	70	70	70	65	57	47	38	33

OX-SB110

span (m) longitud (m)	2-10m	11m	12m	13m	14m	15m	16m	17m	18m	19m	20m	21m	22m
45° WLL (t)	110	105	91	78	67	58	51	44	39	34	30	26	23
30° WLL (t)	110	110	110	110	110	100	88	76	67	58	51	45	40
20° WLL (t)	110	110	110	110	110	110	110	110	105	92	82	70	63

OX-SB110/170

span (m) longitud (m)	2-7m	8m	9m	10m	11m	12m	13m	14m	15m	16m	17m	18m	19m	20m	21m	22m
45° WLL (t)	170	160	140	110	105	91	78	67	58	51	44	39	34	30	26	23
30° WLL (t)	170	170	170	170	170	155	135	110	100	88	76	67	58	51	45	40
20° WLL (t)	170	170	170	170	170	170	170	170	155	140	110	105	92	82	70	63

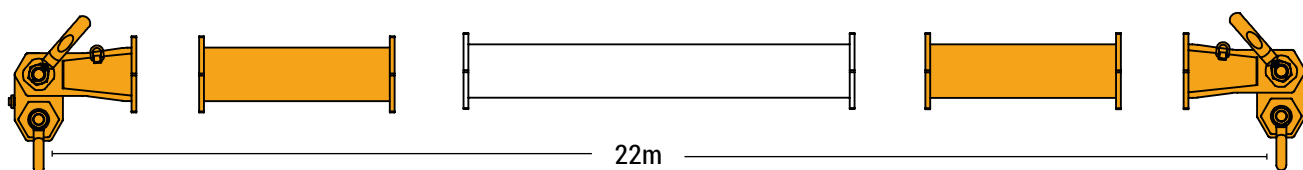

*On average, we have 30% more load capacity in the longer ones

*De media, tenemos un 30% más de capacidad de carga en las de mayor longitud

EXAMPLE IDENTIFICATION TAG
EJEMPLO DE PLACA DE IDENTIFICACION



OX-SB170

span (m) longitud (m)	2-11m	12m	13m	14m	15m	16m	17m	18m	19m	20m	21m	22m	23m	24m
45° WLL (t)	170	162	144	128	112	100	88	78	70	62	55	49	44	40
30° WLL (t)	170	170	170	170	170	170	152	134	120	107	95	84	75	68
20° WLL (t)	170	170	170	170	170	170	170	170	170	170	150	140	120	108

OX-SB170/250

span (m) longitud (m)	2-8m	9m	10m	11m	12m	13m	14m	15m	16m	17m	18m	19m	20m	21m	22m	23m	24m
45° WLL (t)	250	230	200	170	162	144	128	112	100	88	78	70	62	55	49	44	40
30° WLL (t)	250	250	250	250	250	240	220	190	170	152	134	120	107	95	84	75	68
20° WLL (t)	250	250	250	250	250	250	250	250	250	240	210	190	170	150	140	120	108

OX-SB250

span (m) longitud (m)	2-15m	16m	17m	18m	19m	20m	21m	22m	23m	24m	25m	26m
45° WLL (t)	250	225	203	182	165	148	135	122	110	100	90	82
30° WLL (t)	250	250	250	250	250	250	230	210	190	172	155	140
20° WLL (t)	250	250	250	250	250	250	250	250	250	250	245	225

OX-SB250/400

span (m) longitud (m)	2-9m	10m	11m	12m	13m	14m	15m	16m	17m	18m	19m	20m	21m	22m	23m	24m	25m	26m
45° WLL (t)	400	390	365	335	305	275	250	225	203	182	165	148	135	122	110	100	90	82
30° WLL (t)	400	400	400	400	400	400	400	385	350	310	280	250	230	210	190	172	155	140
20° WLL (t)	400	400	400	400	400	400	400	400	400	400	400	400	365	330	300	270	245	225

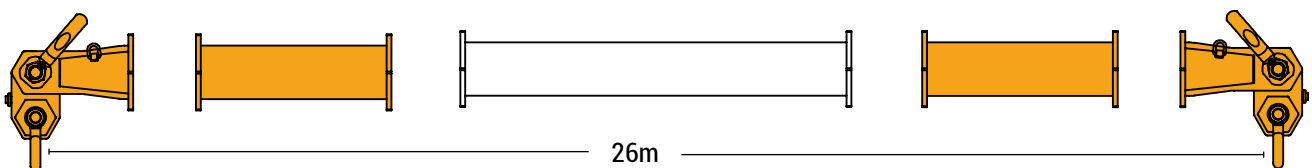

*On average, we have 30% more load capacity in the longer ones

*De media, tenemos un 30% más de capacidad de carga en las de mayor longitud

CAPACITY TABLES

TABLAS DE CAPACIDAD

EXAMPLE
IDENTIFICATION TAG
EJEMPLO DE PLACA DE
IDENTIFICACION



OX-SB400

span (m) longitud (m)	2-18m	19m	20m	21m	22m	23m	24m	25m	26m	27m	28m	29m	30m
45° WLL (t)	400	360	325	292	262	235	218	196	182	165	150	138	128
30° WLL (t)	400	400	400	400	400	400	376	338	314	285	258	238	220
20° WLL (t)	400	400	400	400	400	400	400	400	400	400	400	378	350

OX-SB400/600

span (m) longitud (m)	2-14m	15m	16m	17m	18m	19m	20m	21m	22m	23m	24m	25m	26m	27m	28m	29m	30m
45° WLL (t)	560	550	525	460	400	360	325	292	262	235	218	196	182	165	150	138	128
30° WLL (t)	600	600	600	600	600	600	560	500	450	400	376	338	314	285	258	238	220
20° WLL (t)	600	600	600	600	600	600	600	600	600	600	590	530	500	450	400	378	350

OX-SB600

span (m) longitud (m)	3-17m	18m	19m	20m	21m	22m	23m	24m	25m	26m	27m	28m	29m	30m	31m	32m
45° WLL (t)	560	530	487	432	385	345	310	280	252	230	214	195	180	165	152	140
30° WLL (t)	600	600	600	600	600	590	535	484	436	398	370	337	310	285	262	240
20° WLL (t)	600	600	600	600	600	600	600	600	600	600	585	535	490	452	415	380

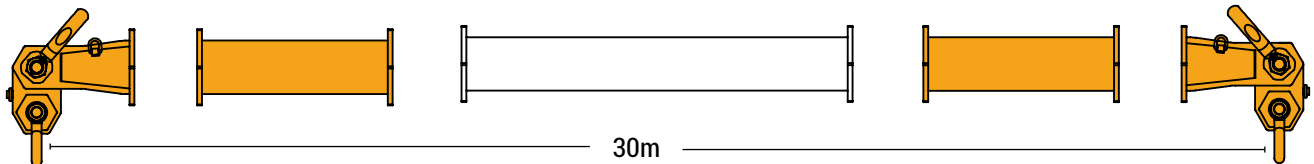

*On average, we have 30% more load capacity in the longer ones

*De media, tenemos un 30% más de capacidad de carga en las de mayor longitud

CAPACITY TABLES

TABLAS DE CAPACIDAD



EXAMPLE IDENTIFICATION TAG

EJEMPLO DE PLACA DE IDENTIFICACION



OX-SB800

span (m) longitud (m)	2-19m	20m	21m	22m	23m	24m	25m	26m	27m	28m	29m	30m	31m	32m	33m	34m
45° WLL (t)	700	670	620	578	530	480	430	380	345	310	280	255	235	215	200	190
30° WLL (t)	800	800	800	800	800	800	744	655	596	535	482	440	405	370	345	328
20° WLL (t)	800	800	800	800	800	800	800	800	800	800	765	700	645	590	545	520

OX-SB1350

span (m) longitud (m)	3-18m	19m	20m	21m	22m	23m	24m	25m	26m	27m	28m	29m	30m	31m	32m	33m	34m	35m	36m
45° WLL (t)	1120	1050	1000	940	870	820	760	710	660	610	570	530	485	440	395	360	320	300	270
30° WLL (t)	1350	1350	1350	1350	1350	1350	1310	1220	1140	1050	985	915	835	760	680	620	550	510	465
20° WLL (t)	1350	1350	1350	1350	1350	1350	1350	1350	1350	1350	1350	1350	1320	1205	1080	980	870	820	740

For more information about other combinations, please contact us,
thank you
Para más información sobre otras combinaciones, póngase en contacto
con nosotros, gracias.

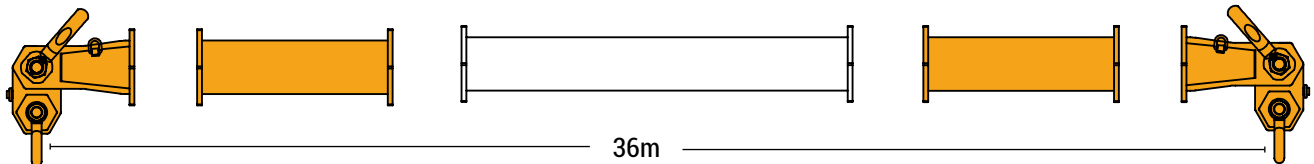

*On average, we have 30% more load capacity in the longer ones

*De media, tenemos un 30% más de capacidad de carga en las de mayor longitud

COMPONENT TABLES

TABLAS DE COMPONENTES

9t - 1350t

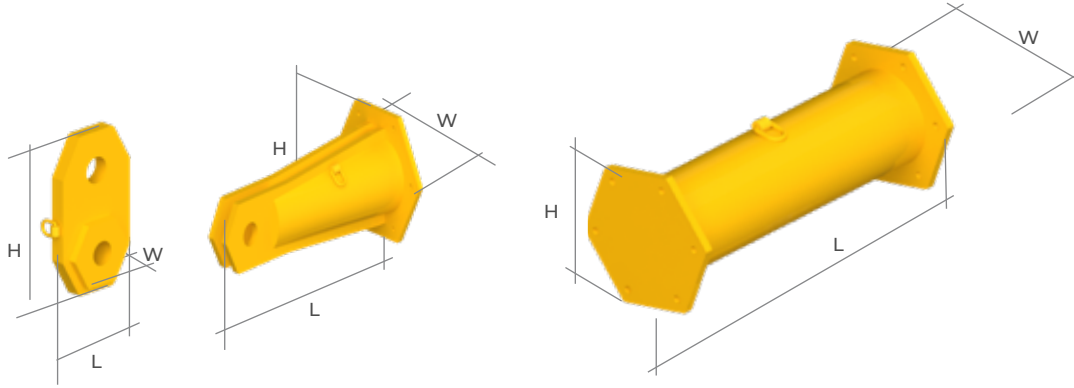

DROP LINK
TERMINAL DESCENDENTE

END UNIT
TERMINAL EXTREMO

SECTION
SECCIÓN

OX-SB9

OX-SB-VERSION2.0

CODE CÓDIGO	DESCRIPTION DESCRIPCIÓN	WEIGHT (KG) PESO (KG)	DIMENSIONS DIMENSIONES L X W X H (MM)
80220009S010	OX-SB-09 SECTION 100mm	4,4	100 x 160 x 140
80220009S030	OX-SB-09 SECTION 300mm	6,1	300 x 160 x 140
80220009S050	OX-SB-09 SECTION 500mm	7,8	500 x 160 x 140
80220009S100	OX-SB-09 SECTION 1000mm	12	1000 x 160 x 140
80220009S200	OX-SB-09 SECTION 2000mm	20,4	2000 x 160 x 140
80220009S300	OX-SB-09 SECTION 3000mm	28,7	3000 x 160 x 140
80220009E	OX-SB-09 END UNIT 250mm	5,2	250 x 160 x 140
80220009D	OX-SB-09 DROP LINK	1,4	88 x 24 x 161
	6,5T - 7/8" BOW SHACKLE SAFETY PIN (TOP)	1,8	
	4,75T - 3/4" BOW SHACKLE SAFETY PIN (BOTTOM)	1,2	
	OX-SB-09 SCREWS (BOXES OF 6 UNITS)	-	DIN 931 M10 x 45 - 10.9

OX-SB17

80220017S025	OX-SB-17 SECTION 250mm	12,8	250 x 220 x 190
80220017S050	OX-SB-17 SECTION 500mm	16,4	500 x 220 x 190
80220017S100	OX-SB-17 SECTION 1000mm	23,2	1000 x 220 x 190
80220017S200	OX-SB-17 SECTION 2000mm	36,7	1000 x 220 x 190
80220017S300	OX-SB-17 SECTION 3000mm	50,1	3000 x 220 x 190
80220017S400	OX-SB-17 SECTION 4000mm	63,6	4000 x 220 x 190
80220017E	OX-SB-17 END UNIT 250mm	10,2	250 x 220 x 190
80220017D	OX-SB-17 DROP LINK	4,1	120 X 36 X 219
	12T - 1 1/4" BOW SHACKLE SAFETY PIN (TOP)	5	
	8,5T - 1" BOW SHACKLE SAFETY PIN (BOTTOM)	2,5	
	OX-SB-17 SCREWS (BOXES OF 6 UNITS)	-	EN-14399 M12 x 60 - 10.9

COMPONENT TABLES

TABLAS DE COMPONENTES

9t - 1350t



OX-SB24

OX-SB-VERSION 2.0

CODE CÓDIGO	DESCRIPTION DESCRIPCIÓN	WEIGHT (KG) PESO (KG)	DIMENSIONS DIMENSIONES L X W X H (MM)
80220024S050	OX-SB-24 SECTION 500mm	25	500 x 290 x 252
80220024S100	OX-SB-24 SECTION 1000mm	33,3	1000 x 290 x 252
80220024S200	OX-SB-24 SECTION 2000mm	50	2000 x 290 x 252
80220024S300	OX-SB-24 SECTION 3000mm	66,5	3000 x 290 x 252
80220024S400	OX-SB-24 SECTION 4000mm	83,1	4000 x 290 x 252
80220024E	OX-SB-24 END UNIT 250mm	16,4	322 x 290 x 252
80220024D	OX-SB-24 DROP LINK	7,3	144 x 45 x 260
	17T - 1 1/2" BOW SHACKLE SAFETY PIN (TOP)	8,4	
	12T - 1 1/4" BOW SHACKLE SAFETY PIN (BOTTOM)	5	
	OX-SB-24 SCREWS (BOXES OF 6 UNITS)	-	EN-14399 M16 x 65 - 10.9

OX-SB34

CODE CÓDIGO	DESCRIPTION DESCRIPCIÓN	WEIGHT (KG) PESO (KG)	DIMENSIONS DIMENSIONES L X W X H (MM)
80220034S050	OX-SB-34 SECTION 500mm	32,8	500 x 340 x 295
80220034S100	OX-SB-34 SECTION 1000mm	42,9	1000 x 340 x 295
80220034S200	OX-SB-34 SECTION 2000mm	63	2000 x 340 x 295
80220034S300	OX-SB-34 SECTION 3000mm	83,2	3000 x 340 x 295
80220034S400	OX-SB-34 SECTION 4000mm	103,3	4000 x 340 x 295
80220034E	OX-SB-34 END UNIT 500mm	35,6	590 x 340 x 295
80220034D	OX-SB-34 DROP LINK	12,6	172 x 54 x 313
	25T - 1 3/4" BOW SHACKLE SAFETY PIN (TOP)	14,5	
	17T - 1 1/2" BOW SHACKLE SAFETY PIN (BOTTOM)	8,4	
	OX-SB-34 SCREWS (BOXES OF 6 UNITS)	-	EN-14399 M20 x 70 - 10.9

OX-SB50

CODE CÓDIGO	DESCRIPTION DESCRIPCIÓN	WEIGHT (KG) PESO (KG)	DIMENSIONS DIMENSIONES L X W X H (MM)
80220050S050	OX-SB-50 SECTION 500mm	55,5	500 x 400 x 347
80220050S100	OX-SB-50 SECTION 1000mm	72	1000 x 400 x 347
80220050S200	OX-SB-50 SECTION 2000mm	105,1	2000 x 400 x 347
80220050S300	OX-SB-50 SECTION 3000mm	138,1	3000 x 400 x 347
80220050S400	OX-SB-50 SECTION 4000mm	171,2	4000 x 400 x 347
80220050S500	OX-SB-50 SECTION 5000mm	204,3	5000 x 400 x 347
80220050S600	OX-SB-50 SECTION 6000mm	237,3	6000 x 400 x 347
80220050E	OX-SB-50 END UNIT 500mm	59	500x 400 x 347
80220050D	OX-SB-50 DROP LINK	17	192x 66 x 355
	35T - 2" BOW SHACKLE SAFETY PIN (TOP)	20	
	25T - 1 3/4" BOW SHACKLE SAFETY PIN (BOTTOM)	14,5	
	OX-SB-50 SCREWS (BOXES OF 6 UNITS)	-	EN-14399 M20 x 80 - 10.9

COMPONENT TABLES

TABLAS DE COMPONENTES

9t - 1350t

OX-SB70

OX-SB-VERSION2.0

CODE CÓDIGO	DESCRIPTION DESCRIPCIÓN	WEIGHT (KG) PESO (KG)	DIMENSIONS DIMENSIONES L X W X H (MM)
80220070S050	OX-SB-70 SECTION 500mm	75,1	500 x 447 x 390
80220070S100	OX-SB-70 SECTION 1000mm	101,2	1000 x 447 x 390
80220070S200	OX-SB-70 SECTION 2000mm	153,5	2000 x 447 x 390
80220070S300	OX-SB-70 SECTION 3000mm	205,8	3000 x 447 x 390
80220070S400	OX-SB-70 SECTION 4000mm	258,1	4000 x 447 x 390
80220070S500	OX-SB-70 SECTION 5000mm	310,4	5000 x 447 x 390
80220070S600	OX-SB-70 SECTION 6000mm	362,6	6000 x 447 x 390
80220070E	OX-SB-70 END UNIT 500mm	85,7	500 x 447 x 390
80220070D	OX-SB-70 DROP LINK	35,8	247 x 76 x 448
	55T - 2 1/2" BOW SHACKLE SAFETY PIN (TOP)	40	GRILLETE LRA TUERCA PASADOR 55T - 2 1/2" (SUPERIOR)
	35T - 2" BOW SHACKLE SAFETY PIN (BOTTOM)	20	GRILLETE LIRA TUERCA PASADOR 35T - 2" (INFERIOR)
	OX-SB-70 SCREWS (BOXES OF 6 UNITS)	-	TORNILLERÍA OX-SB-70 (CAJAS DE 6 UDS.) EN-14399 M20 x 80 - 10.9

OX-SB110

CODE CÓDIGO	DESCRIPTION DESCRIPCIÓN	WEIGHT (KG) PESO (KG)	DIMENSIONS DIMENSIONES L X W X H (MM)
80220110S050	OX-SB-110 SECTION 500mm	110,4	500 x 497 x 433
80220110S100	OX-SB-110 SECTION 1000mm	149,1	1000 x 497 x 433
80220110S200	OX-SB-110 SECTION 2000mm	226,5	2000 x 497 x 433
80220110S300	OX-SB-110 SECTION 3000mm	303,9	3000 x 497 x 433
80220110S400	OX-SB-110 SECTION 4000mm	381,3	4000 x 497 x 433
80220110S500	OX-SB-110 SECTION 5000mm	458,7	5000 x 497 x 433
80220110S600	OX-SB-110 SECTION 6000mm	536,1	6000 x 497 x 433
80220110E	OX-SB-110 END UNIT 1000mm	210,5	1000 x 497 x 433
80220110D	OX-SB-110 DROP LINK	64,2	303 x 90 x 541
	85T - 3" BOW SHACKLE SAFETY PIN (TOP)	62	GRILLETE LIRA - 3" (SUPERIOR)
	55T - 2 1/2" BOW SHACKLE SAFETY PIN (BOTTOM)	40	GRILLETE LIRA TUERCAPASADOR- 2 1/2" (INFERIOR)
	OX-SB-110 SCREWS (BOXES OF 6 UNITS)	-	TORNILLERÍA OX-SB-110 (CAJAS DE 6 UDS.) EN-14399 M20 x 90 - 10.9

OX-SB110/170

CODE CÓDIGO	DESCRIPTION DESCRIPCIÓN	WEIGHT (KG) PESO (KG)	DIMENSIONS DIMENSIONES L X W X H (MM)
80220110S050	OX-SB-110 SECTION 500mm	110,4	500 x 497 x 433
80220110S100	OX-SB-110 SECTION 1000mm	149,1	1000 x 497 x 433
80220110S200	OX-SB-110 SECTION 2000mm	226,5	2000 x 497 x 433
80220110S300	OX-SB-110 SECTION 3000mm	303,9	3000 x 497 x 433
80220110S400	OX-SB-110 SECTION 4000mm	381,3	4000 x 497 x 433
80220110S500	OX-SB-110 SECTION 5000mm	458,7	5000 x 497 x 433
80220110S600	OX-SB-110 SECTION 6000mm	536,1	6000 x 497 x 433
8022110170E	OX-SB-110/170 END UNIT 1000mm	262	1000 x 497 x 433
80220170D	OX-SB-170 DROP LINK	94	342 x 15 x 610
	120T - 3 1/2" BOW SHACKLE SAFETY PIN (TOP)	110	GRILLETE LIRA TUERCA PASADOR 120T - 3 1/2" (SUPERIOR)
	85T - 3" BOW SHACKLE SAFETY PIN (BOTTOM)	62	GRILLETE LIRA TUERCA PASADOR 85T - 3" (INFERIOR)
	OX-SB-110 SCREWS (BOXES OF 6 UNITS)	-	TORNILLERÍA OX-SB-110 (CAJAS DE 6 UDS.) EN-14399 M20 x 90 - 10.9

OX-SB170

OX-SB-VERSION 2.0

CODE CÓDIGO	DESCRIPTION DESCRIPCIÓN	WEIGHT (KG) PESO (KG)	DIMENSIONS DIMENSIONES L X W X H (MM)
80220170S050	OX-SB-170 SECTION 500mm	160,8	500 x 597 x 537
80220170S100	OX-SB-170 SECTION 1000mm	209,7	1000 x 597 x 537
80220170S200	OX-SB-170 SECTION 2000mm	307,4	2000 x 597 x 537
80220170S300	OX-SB-170 SECTION 3000mm	405,2	3000 x 597 x 537
80220170S400	OX-SB-170 SECTION 4000mm	503	4000 x 597 x 537
80220170S500	OX-SB-170 SECTION 5000mm	600,7	5000 x 597 x 537
80220170S600	OX-SB-170 SECTION 6000mm	698,5	6000 x 597 x 537
80220170E	OX-SB-170 END UNIT 1000mm	341	1000 x 597 x 537
80220170D	OX-SB-170 DROP LINK	94	342 x 115 x 610
	120T - 3 1/2" BOW SHACKLE SAFETY PIN (TOP)	110	
	85T - 3" BOW SHACKLE SAFETY PIN (BOTTOM)	62	
	OX-SB-170 SCREWS (BOXES OF 6 UNITS)	-	EN-14399 M20 x 90 - 10.9

OX-SB170/250

CODE CÓDIGO	DESCRIPTION DESCRIPCIÓN	WEIGHT (KG) PESO (KG)	DIMENSIONS DIMENSIONES L X W X H (MM)
80220170S050	OX-SB-170 SECTION 500mm	160,8	500 x 597 x 537
80220170S100	OX-SB-170 SECTION 1000mm	209,7	1000 x 597 x 537
80220170S200	OX-SB-170 SECTION 2000mm	307,4	2000 x 597 x 537
80220170S300	OX-SB-170 SECTION 3000mm	405,2	3000 x 597 x 537
80220170S400	OX-SB-170 SECTION 4000mm	503	4000 x 597 x 537
80220170S500	OX-SB-170 SECTION 5000mm	600,7	5000 x 597 x 537
80220170S600	OX-SB-170 SECTION 6000mm	698,5	6000 x 597 x 537
8022170250E	OX-SB-170/250 END UNIT 1000mm	360	1000 x 597 x 537
80220250D	OX-SB-250 DROP LINK	135,5	395 x 115 x 775
	200T WIDE BODY SHACKLE (TOP)	183	
	RECOMMENDED, BUT OPTIONAL		
	125T WIDE BODY SHACKLE (BOTTOM)	84	
	RECOMMENDED, BUT OPTIONAL		
	OX-SB-170 SCREWS (BOXES OF 6 UNITS)	-	EN-14399 M20 x 90 - 10.9

OX-SB250

CODE CÓDIGO	DESCRIPTION DESCRIPCIÓN	WEIGHT (KG) PESO (KG)	DIMENSIONS DIMENSIONES L X W X H (MM)
80220250S050	OX-SB-250 SECTION 500mm	276,6	500 x 772 x 672
80220250S100	OX-SB-250 SECTION 1000mm	353	1000 x 772 x 672
80220250S200	OX-SB-250 SECTION 2000mm	505,7	2000 x 772 x 672
80220250S300	OX-SB-250 SECTION 3000mm	658,4	3000 x 772 x 672
80220250S400	OX-SB-250 SECTION 4000mm	811,2	4000 x 772 x 672
80220250S500	OX-SB-250 SECTION 5000mm	964	5000 x 772 x 672
80220250S600	OX-SB-250 SECTION 6000mm	1116,7	6000 x 772 x 672
80220250E	OX-SB-250 END UNIT 1000mm	435	1000 x 772 x 672
80220250D	OX-SB-250 DROP LINK	135,5	395 x 115 x 725
-	200T WIDE BODY SHACKLE (TOP)	183	-
	RECOMMENDED, BUT OPTIONAL		
-	125T WIDE BODY SHACKLE (BOTTOM)	84	-
	RECOMMENDED, BUT OPTIONAL		
-	OX-SB-250 SCREWS (BOXES OF 12 UNITS)	-	EN-14399 M24 x 100 - 10.9

COMPONENT TABLES

TABLAS DE COMPONENTES

9t - 1350t

OX-SB250/400

OX-SB-VERSION2.0

CODE CÓDIGO	DESCRIPTION DESCRIPCIÓN	WEIGHT (KG) PESO (KG)	DIMENSIONS DIMENSIONES L X W X H (MM)
80220250S050	OX-SB-250 SECTION 500mm	276,6	500 x 772 x 672
80220250S100	OX-SB-250 SECTION 1000mm	353	1000 x 772 x 672
80220250S200	OX-SB-250 SECTION 2000mm	505,7	2000 x 772 x 672
80220250S300	OX-SB-250 SECTION 3000mm	658,4	3000 x 772 x 672
80220250S400	OX-SB-250 SECTION 4000mm	811,2	4000 x 772 x 672
80220250S500	OX-SB-250 SECTION 5000mm	964	5000 x 772 x 672
80220250S600	OX-SB-250 SECTION 6000mm	1116,7	6000 x 772 x 672
8022250400E	OX-SB-250/400 END UNIT 1000mm	578	1205 x 772 x 672
80220400D	OX-SB-400 DROP LINK	250	508 x 140 x 906
-	300T WIDE BODY SHACKLE (TOP) RECOMMENDED, BUT OPTIONAL	362	-
-	200T WIDE BODY SHACKLE (BOTTOM) RECOMMENDED, BUT OPTIONAL	183	-
-	OX-SB-250 SCREWS (BOXES OF 12 UNITS)	-	EN-14399 M24 x 100 - 10,9

OX-SB400

802204000S50	OX-SB-400 SECTION 500mm	452,9	500 x 937 x 814
802204000S100	OX-SB-400 SECTION 1000mm	570	1000 x 937 x 814
802204000S200	OX-SB-400 SECTION 2000mm	804,5	2000 x 937 x 814
802204000S300	OX-SB-400 SECTION 3000mm	1038,8	3000 x 937 x 814
802204000S400	OX-SB-400 SECTION 4000mm	1273,2	4000 x 937 x 814
802204000S500	OX-SB-400 SECTION 5000mm	1507,6	5000 x 937 x 814
802204000S600	OX-SB-400 SECTION 6000mm	1742	6000 x 937 x 814
80220400E	OX-SB-400 END UNIT 1000mm	696	1000 x 937 x 814
80220400D	OX-SB-400 DROP LINK	250	508 x 140 x 906
-	300T WIDE BODY SHACKLE (TOP) RECOMMENDED, BUT OPTIONAL	362	-
-	200T WIDE BODY SHACKLE (BOTTOM) RECOMMENDED, BUT OPTIONAL	183	-
-	OX-SB-400 SCREWS (BOXES OF 18 UNITS)	-	EN-14399 M24 x 110 - 10,9

OX-SB400/600

802204000S50	OX-SB-400 SECTION 500mm	452,9	500 x 937 x 814
802204000S100	OX-SB-400 SECTION 1000mm	570	1000 x 937 x 814
802204000S200	OX-SB-400 SECTION 2000mm	804,5	2000 x 937 x 814
802204000S300	OX-SB-400 SECTION 3000mm	1038,8	3000 x 937 x 814
802204000S400	OX-SB-400 SECTION 4000mm	1273,2	4000 x 937 x 814
802204000S500	OX-SB-400 SECTION 5000mm	1507,6	5000 x 937 x 814
802204000S600	OX-SB-400 SECTION 6000mm	1742	6000 x 937 x 814
8022400600E	OX-SB-400/600 END UNIT 1000mm	696	1505 x 937 x 814
80220600D	OX-SB-600 DROP LINK	392	571 x 170 x 1020
-	400T WIDE BODY SHACKLE (TOP) RECOMMENDED, BUT OPTIONAL	635	-
-	300T WIDE BODY SHACKLE (BOTTOM) RECOMMENDED, BUT OPTIONAL	362	-
-	OX-SB-400 SCREWS (BOXES OF 18 UNITS)	-	EN-14399 M24 x 110 - 10,9

COMPONENT TABLES

TABLAS DE COMPONENTES

9t - 1350t



OX-SB800

OX-SB-VERSION 2.0

CODE CÓDIGO	DESCRIPTION DESCRIPCIÓN	WEIGHT (KG) PESO (KG)	DIMENSIONS DIMENSIONES L X W X H (MM)
80220800S050	OX-SB-800 SECTION 500mm	721	500 x 1077 x 936
80220800S100	OX-SB-800 SECTION 1000mm	891,5	1000 x 1077 x 936
80220800S200	OX-SB-800 SECTION 2000mm	1232,3	2000 x 1077 x 936
80220800S300	OX-SB-800 SECTION 3000mm	1573	3000 x 1077 x 936
80220800S400	OX-SB-800 SECTION 4000mm	1914	4000 x 1077 x 936
80220800S500	OX-SB-800 SECTION 5000mm	2254,8	5000 x 1077 x 936
80220800S600	OX-SB-800 SECTION 6000mm	2595,6	6000 x 1077 x 936
80220800E	OX-SB-800 END UNIT 1500mm	1593,5	1600 x 1077 x 936
80220800D	OX-SB-800 DROP LINK	577	637 x 210 x 1140
-	500t WIDE BODY SHACKLE (TOP) RECOMMENDED, BUT OPTIONAL	803	-
-	400t WIDE BODY SHACKLE (BOTTOM) RECOMMENDED, BUT OPTIONAL	635	-
-	OX-SB-800 SCREWS (BOXES OF 24 UNITS)		EN-14399 M24 x 130 - 10.9

OX-SB1350

80221350S050	OX-SB-1350 SECTION 500mm	974,8	500 x 1207 x 1048
80221350S100	OX-SB-1350 SECTION 1000mm	1189,3	1000 x 1207 x 1048
80221350S200	OX-SB-1350 SECTION 2000mm	1618,4	2000 x 1207 x 1048
80221350S300	OX-SB-1350 SECTION 3000mm	2047,4	3000 x 1207 x 1048
80221350S400	OX-SB-1350 SECTION 4000mm	2476,5	4000 x 1207 x 1048
80221350S500	OX-SB-1350 SECTION 5000mm	2905,5	5000 x 1207 x 1048
80221350S600	OX-SB-1350 SECTION 6000mm	3334,6	6000 x 1207 x 1048
80221350E	OX-SB-1350 END UNIT 1500mm	2210	1500 x 1207 x 1048
80221350D	OX-SB-1350 DROP LINKT	1343	830 x 270 x 1480
-	800t WIDE BODY SHACKLE (TOP)	1400	-
-	700t WIDE BODY SHACKLE (BOTTOM)	1350	-
-	OX-SB-1350 SCREWS (BOXES OF 24 UNITS)		EN-14399 M27 x 140 - 10.9

OX
WORLDWIDE



**HEAVY
LIFTING
EQUIPMENT**

POSSIBLE APPLICATIONS

POSIBLES APLICACIONES



COMPOSITION FOR LOAD LIFTING WITH 4 ANCHORAGE POINTS IN LINE.

COMPOSICIÓN PARA ELEVACIÓN DE CARGA CON 4 PUNTOS DE ANCLAJE EN LÍNEA.

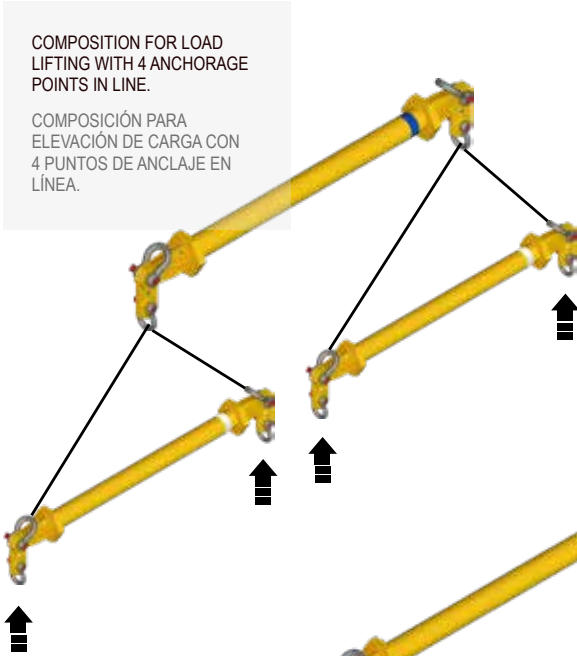

COMPOSITION FOR LOAD LIFTING WITH 4 ANCHORAGE POINTS AT THE ENDS.

COMPOSICIÓN PARA ELEVACIÓN DE UNA CARGA CON 4 PUNTOS DE ANCLAJE EN EXTREMOS.

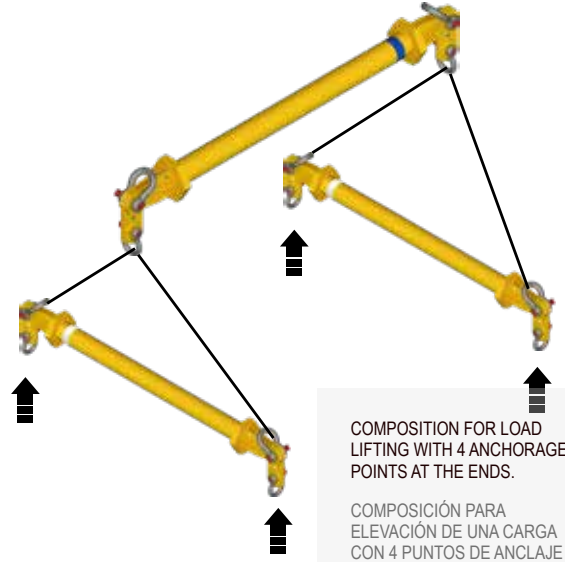

COMPOSITION FOR LOAD LIFTING WITH 8 ANCHORAGE POINTS.

COMPOSICIÓN PARA ELEVACIÓN DE UNA CARGA CON 8 PUNTOS DE ANCLAJE.

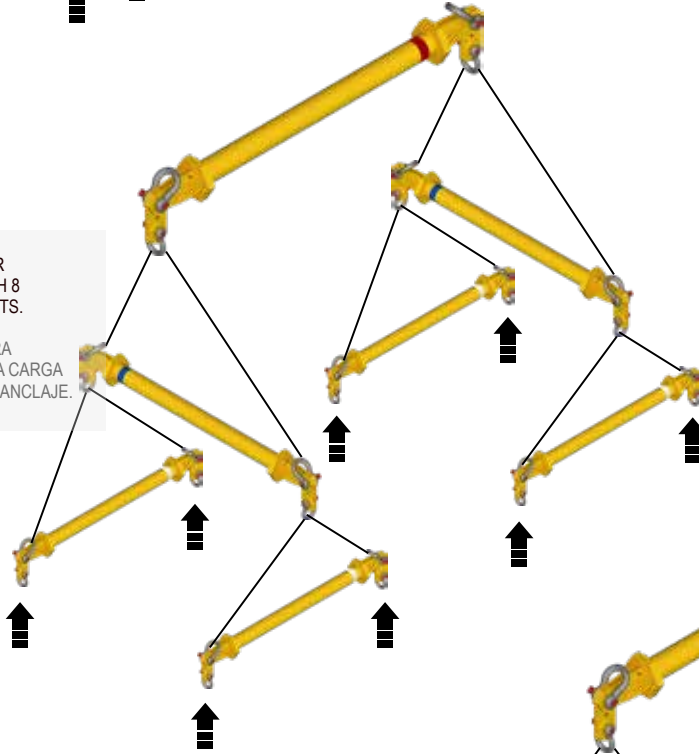

COMPOSITION FOR LOAD LIFTING WITH 8 ANCHORAGE POINTS IN LINE.

COMPOSICIÓN PARA ELEVACIÓN DE UNA CARGA CON 8 PUNTOS DE ANCLAJE EN LÍNEA.

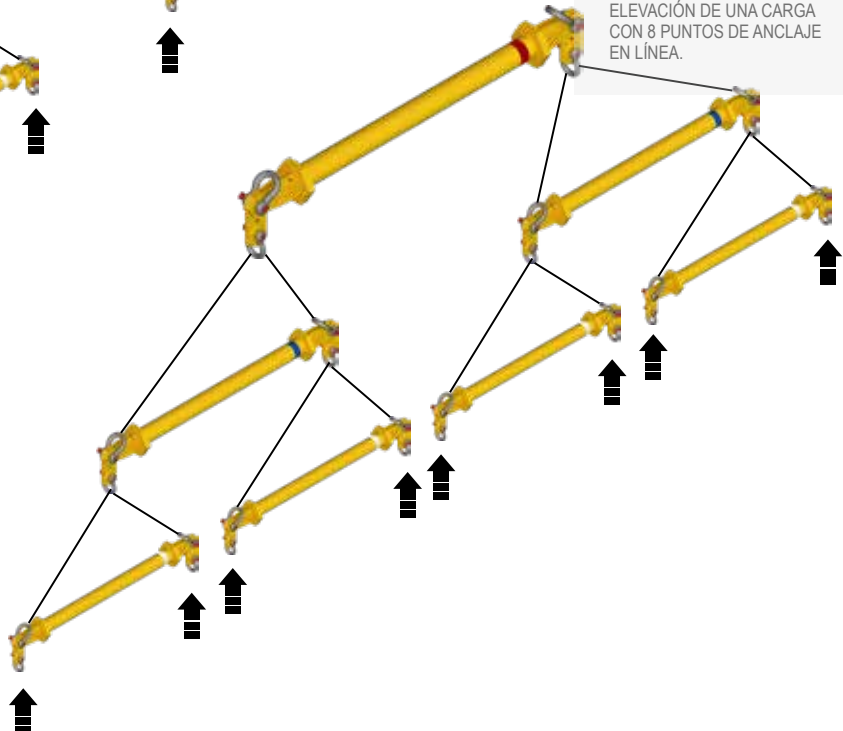

WE CAN ADVISE YOU ON THE USE OF MULTIPLE MODELS FOR YOUR LOAD LIFTING NEEDS.

PODEMOS ASESORARLES EN EL USO DE LOS DIFERENTES MODELOS DEPENDIENDO DE SUS NECESIDADES DE ELEVACIÓN

POSSIBLE APPLICATIONS

POSIBLES APLICACIONES

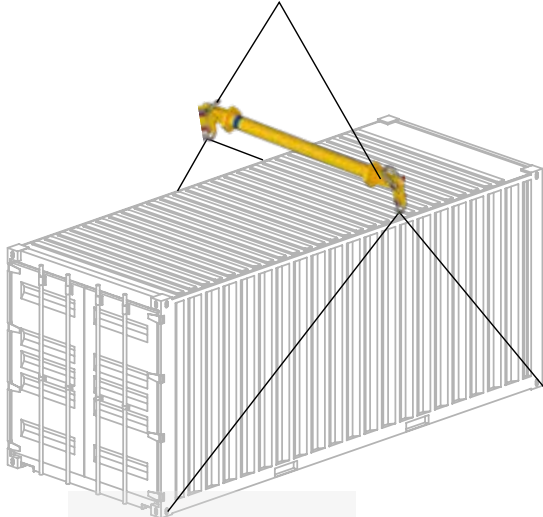

LIFTING OF CONTAINERS WITH 1 ONLY SPREADER AND LATERAL TWISTLOCKS.

ELEVACIÓN DE CONTENEDORES CON 1 SOLO SPREADER Y TWISTLOCKS LATERALES.

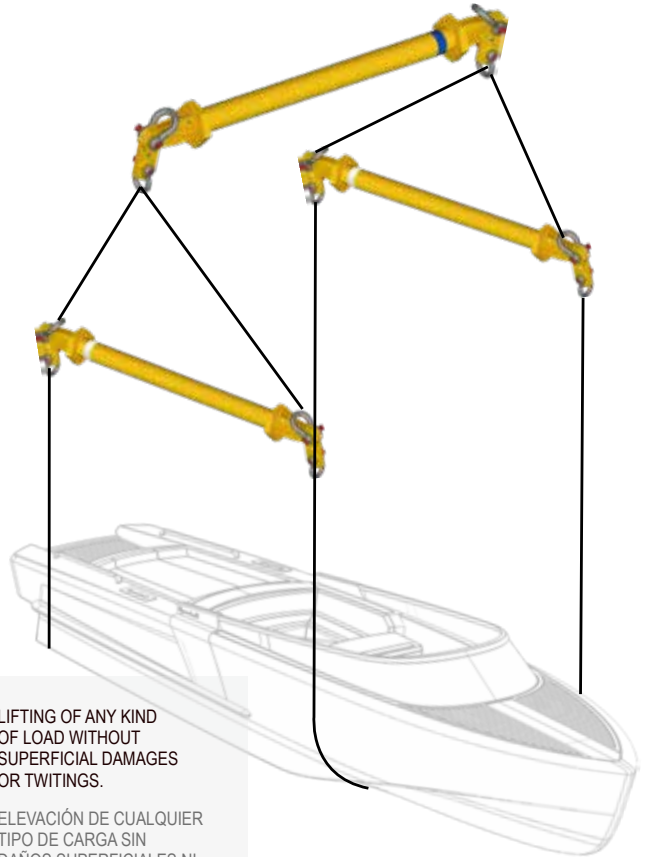

LIFTING OF ANY KIND OF LOAD WITHOUT SUPERFICIAL DAMAGES OR TWISTINGS.

ELEVACIÓN DE CUALQUIER TIPO DE CARGA SIN DAÑOS SUPERFICIALES NI TORSIONES.

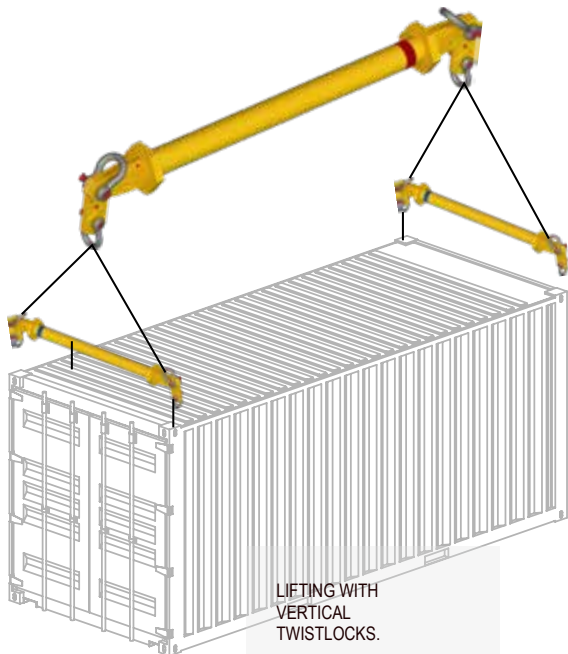

LIFTING WITH VERTICAL TWISTLOCKS.

ELEVACIÓN CON TWISTLOCKS VERTICALES.

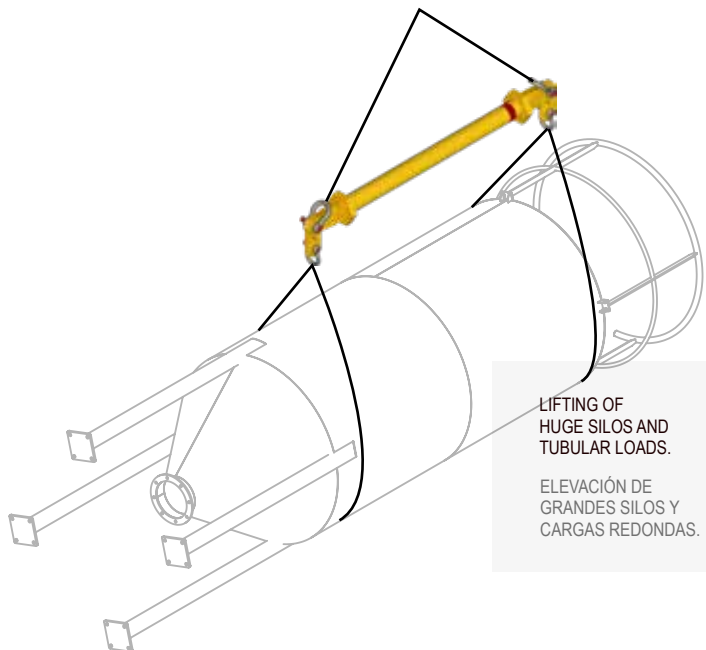

LIFTING OF HUGE SILOS AND TUBULAR LOADS.

ELEVACIÓN DE GRANDES SILOS Y CARGAS REDONDAS.

CORNERS AND CONE ADAPTERS

CORNERS Y ADAPTADORES CÓNICOS



Corners are used to join several spreaders into a frame. They are modular, easy to assemble and disassemble and can be adapted to various configurations and sizes



Los Corners se utilizan para unir varios spreaders en un marco. Son modulares, fáciles de montar y desmontar y se pueden adaptar a diversas configuraciones y tamaño

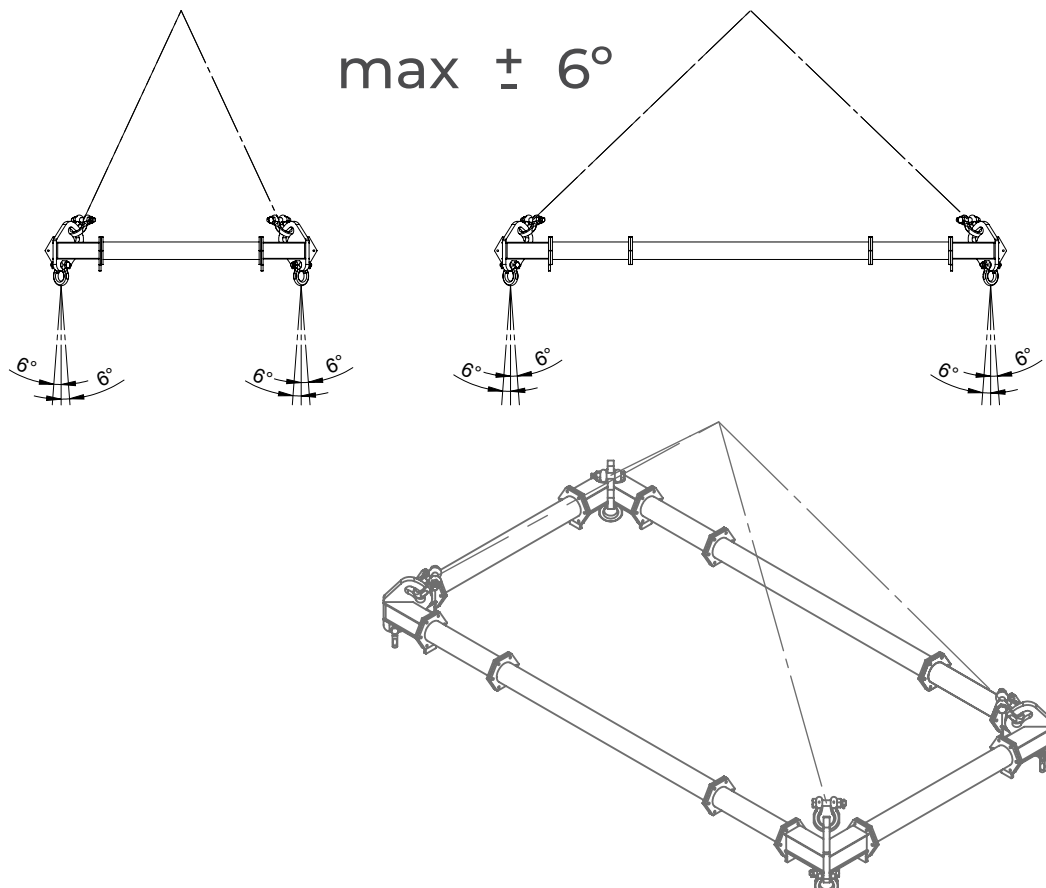

CAPACITY TABLE

TABLAS DE CAPACIDAD

CU-OX-SB09 - 30°

Span [m]	30° SWL [Tons]									
	0,5	1	1,5	2	2,5	3	3,5	4	4,5	5
5										12
4,5									12	12
4								12	12	12
3,5							12	12	12	12
3						12	12	12	12	12
2,5					12	12	12	12	12	12
2				12	12	12	12	12	10	10
1,5			12	12	12	12	12	10	8	8
1		12	12	12	10	8	8	8	7	7
0,5	12	12	12	9	9	7	7	7	6	6

CU-OX-SB09 - 45°

Span [m]	45° SWL [Tons]									
	0,5	1	1,5	2	2,5	3	3,5	4	4,5	5
5										10
4,5									10	10
4								10	10	10
3,5							10	10	10	10
3						10	10	10	10	10
2,5					10	10	10	10	10	10
2				10	10	10	10	10	8	8
1,5			10	10	10	10	10	8	6	6
1		10	10	10	6	6	6	6	5	5
0,5	10	10	10	6	6	5	5	5	4	4

(c/u) = cada uno

Cjto= conjunto equivalente a 4 corners

*ver tabla de carga

DIMENSIONS (MM) DIMENSIONES	WEIGHT (KG) PESO (KG)	CAPACITY CAPACIDAD	SCREWS TORNILLOS	SHACKLE TOP GRILLETE SUP	SHACKLE BOTTON GRILLETE INF.
250x250x250	17,5	3 (c/u) 12 cjtto*	931 M10x45 - 10.9	6.5	4.75

CAPACITY TABLE

TABLAS DE CAPACIDAD



CU-OX-SB017 - 30°

CU-OX-SB017 - 45°

Span [m]	0,5	1	1,5	2	2,5	3	3,5	4	4,5	5	5,5	6	6,5	7	7,5	8	8,5	9	9,5	10							
10																				12	12						
9,5																			12	12	12						
9																	14	12	12	12	12						
8,5																16	14	12	11	11	11						
8															18	16	14	12	11	11	11						
7,5														21	18	16	14	12	11	10	10						
7													24	21	16	14	14	11	10	10	10						
6,5												24	24	20	16	14	12	11	10	10	10						
6											24	24	22	20	16	14	12	11	10	10	10						
5,5									24	24	22	22	20	14	14	12	11	10	9	9	9						
5								24	24	22	22	20	18	14	14	12	10	10	9	9	9						
4,5								24	24	22	22	20	18	18	14	12	10	10	9	9	9						
4								24	24	22	22	20	18	18	16	12	12	10	9	9	9						
3,5								24	24	22	22	20	18	18	16	14	12	10	9	9	9						
3								24	24	22	22	21	20	18	17	15	13	12	10	9	9						
2,5								24	24	22	22	21	20	19	17	16	15	13	12	11	9	9					
2								24	24	24	22	21	20	19	18	16	15	15	13	12	11	9	9				
1,5								24	24	24	24	22	20	19	18	17	15	15	14	13	12	11	11	9	9		
1								24	24	24	24	24	22	19	18	17	16	15	14	13	13	12	11	11	9	9	
0,5								24	24	24	24	24	24	22	18	18	16	16	14	14	13	13	12	11	11	9	9

Span [m]	0,5	1	1,5	2	2,5	3	3,5	4	4,5	5	5,5	6	6,5	7	7,5	8	8,5	9	9,5	10														
10																					7	7												
9,5																					7	7	7											
9																			8	7	7	7	7											
8,5																		9	8	7	7	7	7											
8																	10	9	8	7	7	7	7											
7,5																12	10	9	8	7	7	7	7											
7															14	12	10	9	8	7	7	7	7											
6,5															16	14	12	10	9	8	7	7	7											
6															18	16	14	12	10	9	8	7	7											
5,5															18	17	16	14	11	10	9	8	7	7										
5															18	17	16	15	13	11	10	9	8	7	6									
4,5															18	18	16	15	14	12	11	9	8	8	7	6								
4															18	18	16	15	14	12	11	10	9	8	8	6	6							
3,5															18	18	16	15	14	12	12	10	10	9	8	8	6	6						
3															18	18	16	15	14	12	12	10	10	10	9	8	7	6	6					
2,5															18	18	16	15	14	12	12	10	10	10	10	9	8	7	6	6				
2															18	18	16	15	14	12	12	10	10	10	10	10	9	8	7	6	6			
1,5															18	18	18	16	14	12	12	10	10	10	10	9	9	8	7	6	6			
1															18	18	18	18	16	14	12	12	10	10	10	10	9	9	8	8	7	6	6	
0,5															18	18	18	18	18	16	14	12	12	10	10	10	9	9	8	8	8	7	6	6

DIMENSIONS (MM) DIMENSIONES	WEIGHT (KG) PESO (KG)	CAPACITY CAPACIDAD	SCREWS TORNILLOS	SHACKLE TOP GRILLETE SUP	SHACKLE BOTTON GRILLETE INF.
250x250x320	35,5	3 (c/u) 12 cjt0*	EN-14399-4 M12x60 -10.9	12	8.5

CAPACITY TABLE

TABLAS DE CAPACIDAD

CU-OX-SB024 - 30°

		30° SWL [Tons]											
Span [m]	12												15
	11											18	15
	10									22	17	14	
	9								26	21	16	14	
	8						28	25	20	15	13		
	7						28	25	22	18	15	13	
	6					28	25	22	21	17	14	12	
	5				35	25	22	21	19	15	13	12	
	4			35	28	22	21	19	17	14	12	11	
	3		35	35	28	21	19	17	15	13	12	11	
	2	35	35	35	28	19	17	15	14	13	12	10	
	1	35	35	35	28	26	17	15	14	13	12	10	10
		12	34	56	78	91	01	11	2				
		Span [m]											

CU-OX-SB024 - 45°

		45° SWL [Tons]											
Span [m]	12											8	
	11										10	8	
	10									12	10	8	
	9								16	12	9	7	
	8						18	16	11	8	7		
	7						18	16	14	10	8	7	
	6					18	16	14	14	10	8	7	
	5				23	16	14	14	12	10	8	7	
	4			26	18	14	14	12	12	10	8	7	
	3		26	26	18	14	12	12	10	9	8	7	
	2	26	26	23	18	12	12	10	9	8	7	6	
	1	26	26	26	18	16	12	10	9	8	7	6	6
		1	2	3	4	5	6	7	8	9	10	11	12
		Span [m]											

(c/u) = cada uno

Cjto= conjunto equivalente a 4 corners

*ver tabla de carga

DIMENSIONS (MM)

DIMENSIONES

500x500x415

WEIGHT (KG)

PESO (KG)

74,5

CAPACITY

CAPACIDAD

8.75(c/u) 35 cjto*

SCREWS

TORNILLOS

EN-14399-4 M16x65 -10.9

SHACKLE TOP

GRILLETE SUP

17

SHACKLE BOTTON

GRILLETE INF.

12

CAPACITY TABLE

TABLAS DE CAPACIDAD



		30° SWL [Tons]																							
14														20											
13													22	20											
12												26	21	19											
11												30	24	20	19										
10												30	28	22	19	18									
9												30	28	27	21	18	17								
8												30	28	27	25	19	17	16							
7												40	28	27	25	23	17	16	15						
6												50	38	27	25	23	21	17	16	15					
5												50	50	34	25	23	21	19	16	15	14				
4												50	50	42	31	23	21	19	18	15	15	14			
3												50	50	50	42	28	21	19	18	17	15	14	14		
2												50	50	50	50	40	26	19	18	17	16	14	14	14	
1												50	50	50	50	42	37	24	18	17	16	15	14	14	14
	1	2	3	4	5	6	7	8	9	10	11	12	13	14											

Span [m]

		45° SWL [Tons]																																		
14																								10												
13																							12	10												
12																						14	12	10												
11																						18	14	12	10											
10																						20	18	14	11	10										
9																						20	18	17	13	11	10									
8																						20	18	17	16	13	11	9								
7																						26	20	17	16	15	12	10	9							
6																						32	24	17	16	15	14	12	10	9						
5																						40	32	23	16	15	14	12	12	10	9					
4																						40	40	28	22	15	14	12	12	11	10	8				
3																						40	40	37	28	19	14	12	12	11	10	9	8			
2																						40	40	40	40	32	26	18	12	12	11	10	9	8	8	
1																						40	40	40	40	40	28	25	17	12	11	10	9	8	8	8
	1	2	3	4	5	6	7	8	9	10	11	12	13	14																						

Span [m]

CU-OX-SB034 - 30°

CU-OX-SB034 - 45°

DIMENSIONS (MM) DIMENSIONES	WEIGHT (KG) PESO (KG)	CAPACITY CAPACIDAD	SCREWS TORNILLOS	SHACKLE TOP GRILLETE SUP	SHACKLE BOTTOM GRILLETE INF.
500x500x523	110	12.5 (c/u) 50 cjt0*	EN-14399-4 M20x70 -10.9	25	17

CAPACITY TABLE

TABLAS DE CAPACIDAD

CU-OX-SB050 - 30°

Span [m]	30° SWL [Tons]															
	16															
15															38	35
14														38	35	33
13													40	35	33	32
12												40	35	33	32	31
11											48	35	33	32	31	30
10										60	45	33	32	31	30	29
9								60	57	42	32	31	30	29	28	28
8							72	60	53	39	31	30	29	28	27	26
7						72	72	60	50	36	30	29	28	27	26	24
6					72	72	72	60	46	35	29	28	27	26	24	22
5				72	72	72	72	60	58	43	34	28	27	26	25	22
4			72	72	72	72	72	60	55	41	33	27	26	25	22	21
3		72	72	72	72	72	72	60	48	40	32	27	26	25	22	21
2	72	72	72	72	72	72	72	60	48	40	32	27	25	22	21	20
1	72	72	72	72	72	72	72	52	46	36	27	25	22	21	20	20
	1	2	3	4	5	6	7	8	9	10	11	12	13	14	15	16

CU-OX-SB050 - 45°

Span [m]	45° SWL [Tons]															
	16															
15															20	18
14														22	19	17
13													22	20	18	16
12												22	20	18	17	16
11											24	20	18	17	16	15
10										30	22	18	17	16	16	15
9									30	28	21	17	16	16	15	14
8									37	30	26	20	16	16	15	14
7									44	37	30	25	19	16	15	14
6									44	44	37	30	24	18	15	14
5									56	44	44	30	30	22	18	15
4									56	56	44	44	30	28	22	17
3									56	56	56	44	37	30	27	21
2									56	56	56	56	44	37	30	27
1									56	56	56	56	44	37	30	27
	1	2	3	4	5	6	7	8	9	10	11	12	13	14	15	16

(c/u) = cada uno

Cjto= conjunto equivalente a 4 corners

*ver tabla de carga

DIMENSIONS (MM)
DIMENSIONES

500x500x620

WEIGHT (KG)
PESO (KG)

185

CAPACITY
CAPACIDAD

18 (c/u) 72 cjto*

SCREWS
TORNILLOS

EN-14399-4 M20x80 -10.9

SHACKLE TOP
GRILLETE SUP

35

SHACKLE BOTTOM
GRILLETE INF.

25

CAPACITY TABLE

TABLAS DE CAPACIDAD

CU-OX-SB110 - 30°

Span [m]	30° SWL [Tons]																						
	1	2	3	4	5	6	7	8	9	10	11	12	13	14	15	16	17	18	19	20	21	22	
22																					110	98	100
21																				110	105	96	
20																		120	105	100	94		
19																	125	120	100	95	90		
18																135	125	115	95	92	88		
17															150	135	120	110	92	90	84		
16														160	145	130	115	108	90	88	82		
15													165	160	140	125	110	105	88	86	78		
14												170	165	158	135	120	105	100	86	84	74		
13											170	170	160	155	130	115	100	95	84	80	72		
12										170	170	170	160	150	125	110	95	90	80	78	68		
11									170	170	170	170	155	150	120	105	90	85	75	72	62		
10								170	170	170	170	170	155	150	120	105	90	85	78	75	64		
9							170	170	170	170	170	170	155	145	110	100	85	80	75	72	62		
8						170	170	170	170	170	170	170	145	140	100	90	80	75	72	70	58		
7					170	170	170	170	170	170	170	150	140	125	90	85	75	72	70	65	56		
6					170	170	170	170	170	170	155	140	125	100	85	80	72	70	65	60	54		
5				170	170	170	170	170	170	170	155	140	130	110	90	80	75	70	65	62	58	52	
4			170	170	170	170	170	170	170	155	140	130	110	100	85	75	70	65	62	58	55	48	
3		170	170	170	170	170	170	170	155	140	130	110	100	85	77	70	65	62	58	55	50	46	
2	170	170	170	170	170	170	155	140	130	110	100	85	77	70	65	62	58	55	50	48	44	42	
1	170	170	170	170	170	170	155	140	130	110	100	85	77	70	65	62	58	55	50	48	44	40	

CU-OX-SB110 - 45°

Span [m]	45° SWL [Tons]																						
	1	2	3	4	5	6	7	8	9	10	11	12	13	14	15	16	17	18	19	20	21	22	
22																					65	60	60
21																				65	64	58	
20																		70	64	62	56		
19																	75	70	64	60	56		
18																80	75	68	62	58	54		
17															85	80	74	66	62	56	54		
16														90	82	78	72	64	60	54	52		
15													104	90	80	76	70	62	60	52	50		
14												115	102	90	76	74	68	60	58	50	48		
13											115	115	100	88	74	72	67	58	55	48	46		
12										115	115	110	105	96	84	72	70	65	55	52	46	44	
11									115	115	110	105	96	84	70	65	60	52	48	44	42		
10								115	115	110	105	100	95	82	65	60	55	48	45	42	40		
9							115	115	110	105	100	90	80	60	55	50	45	42	40	38	36		
8						115	115	115	110	105	100	90	80	70	55	50	45	42	40	38	36		
7						115	115	115	110	105	100	90	80	70	55	50	45	42	40	38	36		
6					115	115	115	115	110	100	95	80	70	60	55	45	42	40	38	36	34		
5					115	115	115	115	110	100	95	80	72	60	55	50	42	40	38	36	34	32	
4				115	115	115	115	115	100	95	80	75	65	60	50	45	40	38	36	34	32	30	
3			115	115	115	115	115	115	95	80	75	65	60	50	45	40	38	36	34	32	30	28	
2		115	115	115	115	115	115	95	80	75	65	60	50	45	40	38	36	34	32	30	28	26	
1	115	115	115	115	115	115	95	80	75	65	60	50	45	40	38	36	34	32	30	28	26	24	

(c/u) = cada uno

Cjto= conjunto equivalente a 4 corners

*ver tabla de carga

DIMENSIONS (MM)

DIMENSIONES

500x500x843

WEIGHT (KG)

PESO (KG)

371

CAPACITY

CAPACIDAD

42.5 (c/u) 170 cjto*

SCREWS

TORNILLOS

EN-14399-4 M20x90 -10.9

SHACKLE TOP

GRILLETE SUP

85

SHACKLE BOTTOM

GRILLETE INF.

55

CAPACITY TABLE

TABLAS DE CAPACIDAD



30° SWL [Tons]

Span [m]	24																							125
	23																						125	120
	22																					140	120	120
	21																				155	135	120	115
	20																			170	150	130	115	110
	19																		180	170	145	130	115	110
	18																	195	180	165	140	125	110	105
	17																215	195	180	160	135	125	110	105
	16															230	215	190	175	155	130	120	110	105
	15														240	230	215	190	175	150	130	120	110	105
	14													250	240	230	210	185	170	145	125	115	105	100
	13												250	250	240	220	210	185	170	140	125	115	105	100
	12											250	250	250	240	220	205	180	165	135	120	110	100	95
	11										250	250	250	250	240	210	205	180	160	130	120	105	95	90
	10									250	250	250	250	250	240	210	185	170	160	125	110	100	90	82
	9								250	250	250	250	250	250	210	200	170	160	136	110	105	95	82	76
	8							250	250	250	250	250	250	210	200	170	160	136	124	105	95	82	76	70
	7						250	250	250	250	250	250	225	200	170	160	136	124	105	95	82	76	70	66
	6					250	250	250	250	250	250	225	200	170	160	136	124	105	95	82	76	70	66	60
	5				250	250	250	250	250	250	225	200	170	160	136	124	105	95	82	76	70	66	60	56
	4			250	250	250	250	250	250	225	200	170	160	136	124	105	95	82	76	70	66	60	56	54
	3		250	250	250	250	250	250	225	200	175	160	136	124	105	95	82	76	70	66	60	56	54	52
	2	250	250	250	250	250	250	225	208	175	160	136	124	105	95	82	76	70	66	60	56	54	52	50
		2	3	4	5	6	7	8	9	10	11	12	13	14	15	16	17	18	19	20	21	22	23	24

CU-OX-SB170 - 30°

45° SWL [Tons]

Span [m]	24																							85	
	23																						95	82	82
	22																					105	92	82	78
	21																				116	102	88	78	75
	20																			122	116	99	88	78	75
	19																		133	122	112	95	85	75	71
	18																	146	133	122	109	92	85	75	71
	17																156	146	129	119	105	88	82	75	71
	16															163	156	146	129	119	102	88	82	75	71
	15														170	163	156	143	126	116	99	85	78	71	68
	14													170	170	163	150	143	126	116	95	85	78	71	68
	13												170	170	170	163	150	139	122	112	92	82	75	68	65
	12											170	170	170	170	163	143	139	122	109	88	82	71	65	61
	11										170	170	170	170	170	163	143	126	116	109	85	75	68	61	56
	10									170	170	170	170	170	143	136	116	109	92	75	71	65	56	52	
	9								170	170	170	170	170	143	136	116	109	92	84	71	65	56	52	48	
	8							170	170	170	170	170	143	136	116	109	92	84	71	65	56	52	48		
	7						170	170	170	170	170	153	136	116	109	92	84	71	65	56	52	48	45		
	6					170	170	170	170	170	170	153	136	116	109	92	84	71	65	56	52	48	45	41	
	5				170	170	170	170	170	170	153	136	116	109	92	84	71	65	56	52	48	45	41	38	
	4			170	170	170	170	170	170	153	136	116	109	92	84	71	65	56	52	48	45	41	38	37	
	3		170	170	170	170	170	170	153	136	119	109	92	84	71	65	56	52	48	45	41	38	37	35	
	2	170	170	170	170	170	170	153	141	119	109	92	84	71	65	56	52	48	45	41	38	37	35	34	
		2	3	4	5	6	7	8	9	10	11	12	13	14	15	16	17	18	19	20	21	22	23	24	

CU-OX-SB170 - 45°

DIMENSIONS (MM) DIMENSIONES	WEIGHT (KG) PESO (KG)	CAPACITY CAPACIDAD	SCREWS TORNILLOS	SHACKLE TOP GRILLETE SUP	SHACKLE BOTTON GRILLETE INF.
1000x1000x1046	759	62.5 (c/u) 250 cjt*	EN-14399-4 M20x90 -10.9	1201	85

CONE ADAPTERS ADAPTADORES CÓNICOS

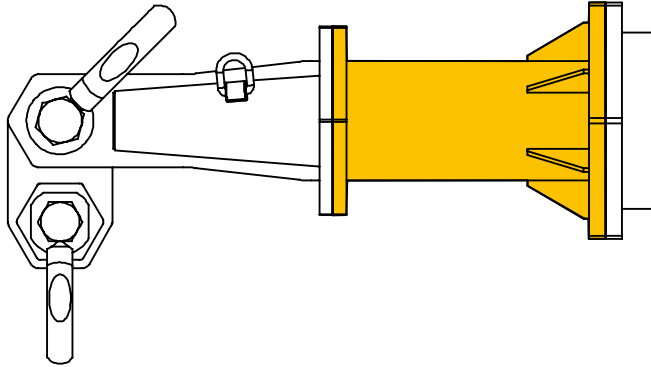

Do you have to lift a very long load but not so heavy?
The conic adapters are the solution.

Reduce the end units of the spreaders to use the shackle that corresponds to the actual load.

Benefits:
Reduction the upper and lower shackles in size and cost.
Smaller (and cheaper) end units and drop links.



¿Tienes que elevar una carga muy larga pero poco pesada?
Los adaptadores cónicos son la solución.

Reducen las puntas de los separadores para conseguir utilizar el grillete que le corresponde a la carga.

Beneficios:
Reducción de los grilletes superiores e inferiores en tamaño y coste.
Puntas y bajantes mas económicos.

POSSIBLE LINKS COMBINACIONES POSIBLES

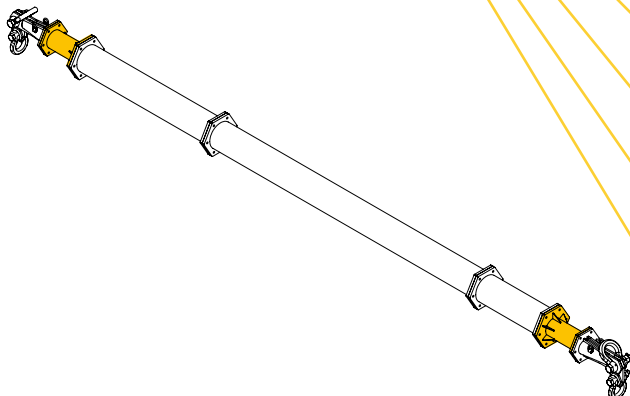

CONE ADAPTERS ADAPTADORES CÓNICOS		CONE ADAPTERS ADAPTADORES CÓNICOS	
SECTION SECCION	END-UNIT TERMINAL	SECTION SECCION	END-UNIT TERMINAL
34	17	250	170
50	17	400	70
50	24	400	110
70	24	400	170
70	34	400	250
70	50	600	110
110	24	600	170
110	34	600	250
110	50	600	400
110	70	800	170
170	34	800	250
170	50	800	400
170	70	800	600
170	110	1350	250
250	50	1350	400
250	70	1350	600
250	110	1350	800